



GUIL®

ULK 650XL



6.50 m

(21.32 ft)

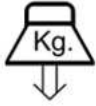

400 kg

(882 lb)



MADE IN SPAIN



www.guil.es



GUIL®

ULK 650XL

ELEVADORES CON 3 SISTEMAS DE SEGURIDAD



Ref. **BULL500/2**

CABRESTANTE AUTOFRENABLE CON DOBLE MANIVELA DESMONTABLE. CERTIFICADO CONFORME A LAS NORMATIVAS EUROPEAS.



SISTEMA DE SEGURIDAD DE BLOQUEO AUTOMÁTICO (ASB)



SISTEMA DE FRENO PENDULAR INTERNO (IPB)



SISTEMA DE DESBLOQUEO DE LOS TRAMOS (MSU)



SISTEMA DE CONTROL SECUENCIAL DE LOS TRAMOS (MSC)



MAYOR TRAMO DE SEGURIDAD. > EVITA EFECTO CAÑA DE PESCAR.

CERTIFIED

DGUV Regulation 17&18

MADE IN SPAIN



CARACTERÍSTICAS TÉCNICAS		ULK 650XL
ALTURA DE TRABAJO	HORQUILLAS SUBIDAS	6,50 m
	HORQUILLAS BAJADAS	6,00 m
CARGA MÁXIMA		400 kg
PESO NETO		202 kg
MEDIDAS PLEGADA		540 x 760 x 1992 mm
ALTURA DE CARGA		30 cm
Nº DE TRAMOS		4
MEDIDA DEL PERFIL		208 mm
CABRESTANTE AUTOFRENABLE		Ref. BULL500/2 2 PALANCAS
CARGA MÍNIMA		20 kg
MATERIAL		ALUMINIO: EN-AW 6082 T6 - ACERO: S235 JRH
COLOR		NEGRO
CONFORME CON		DGUV Regulation 17&18, DGUV Rule 115-002, DIN 56950-1, 2006/42/CE



GUIL®

ULK 650XL

MADE IN SPAIN



LINE ARRAY

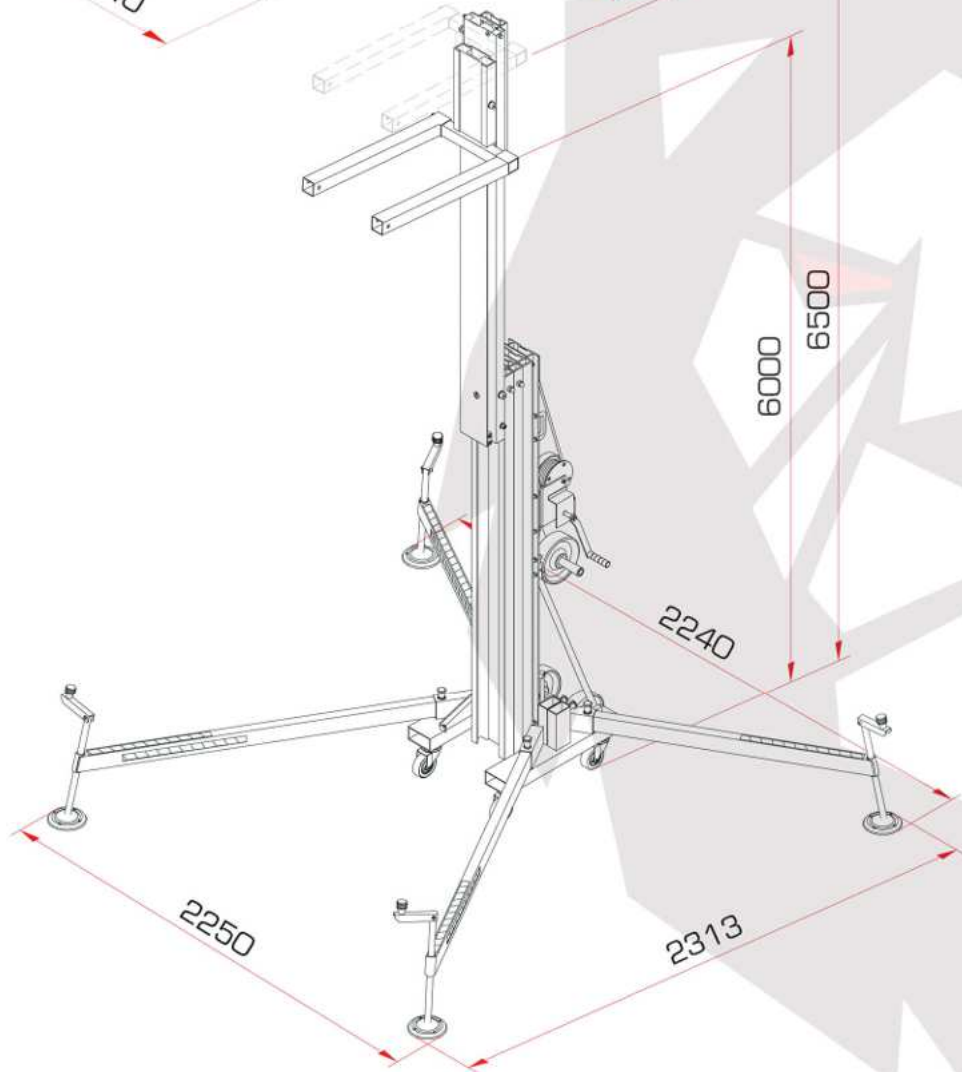
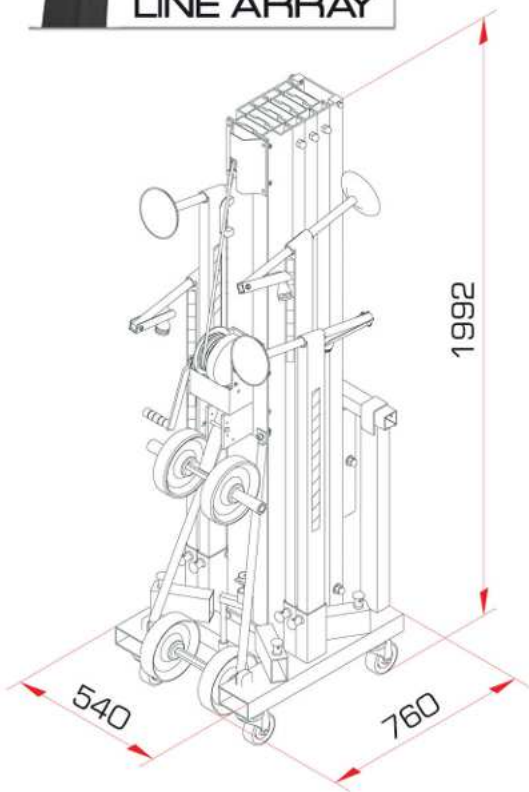
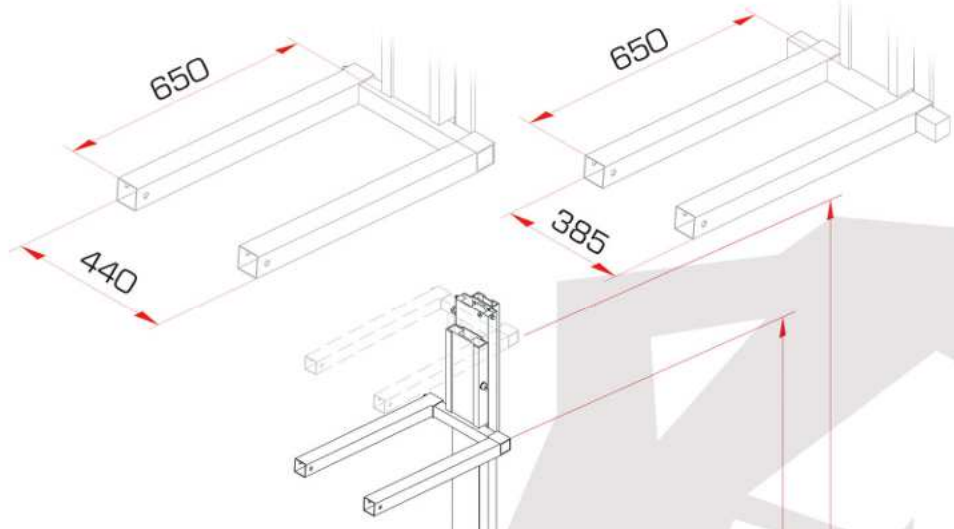

ADAPTADORES PARA ULK

ADAPTADORES PARA LA ELEVACIÓN DE SISTEMAS LINE ARRAY

ADAPTADOR ARTICULADO PARA ELEVAR TRUSSES CON TORRES ULK



Ref. **ULK-A6**



Ref. **ULK-A4**



Ref. **ULK-A10**



GUIL®

ELEVADORES DE CARGA FRONTAL

ULK



CE

DGUV Regulation 17&18

Detalles que nos diferencian



Sistema de desbloqueo de los tramos (MSU)



Sistema de seguridad de Bloqueo Automático (ASB)



Ref. **BULL500/2**

Cabrestante Autofrenable con doble manivela desmontable. Certificado Conforme a las normativas Europeas.



Sistema de Freno Pendular Interno (IPB)

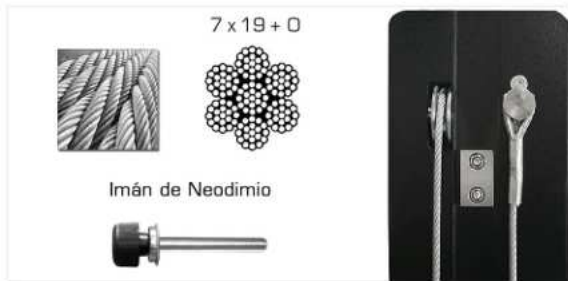

Perfiles de Aluminio reforzado, Cable galvanizado, Pasadores de acero inoxidable con imán de Neodimio.



Sistema de reenvío con poleas de acero.



4 ruedas (Ø100mm) con núcleo de aluminio y placa de sujeción de acero.



Equipados con 4 estabilizadores de refuerzo para una máxima resistencia.



Husillos niveladores de doble paso y velocidad con discos cromados con caucho antideslizante.



2 Ruedas reforzadas de Ø200 mm, para el transporte en posición horizontal y facilitar su carga en vehículos.



Pletina de acero sobredimensionada en "U" para sujeción del mástil a la base. Adaptador portadocumentos.



Mayor tramo de seguridad. > Evita efecto caña de pescar.



Empuñadura abatible con 2 Ruedas reforzadas (Ø200mm) para el transporte en horizontal y su carga en vehículos.



Provistos con horquillas reforzadas de 60x60 mm. Máxima resistencia. Diseño desmontable y ajustable. Soporte Horquillas con 2 posiciones.