



GUIL®

ULK 500

↑ **6.30 m**
(20.70 ft)

Kg. **220 kg**
(485 lb)



1700 mm



MADE IN SPAIN



www.guil.es



GUIL®

ULK 500

ELEVADORES CON 3 SISTEMAS DE SEGURIDAD



Ref. **AL-KO 900**

CABRESTANTE AUTOFRENABLE
CERTIFICADO CONFORME A LAS NORMATIVAS EUROPEAS.



SISTEMA DE SEGURIDAD DE BLOQUEO AUTOMÁTICO (ASB)



SISTEMA DE FRENO PENDULAR INTERNO (IPB)



SISTEMA DE DESBLOQUEO DE LOS TRAMOS (MSU)



SISTEMA DE CONTROL SECUENCIAL DE LOS TRAMOS (MSC)

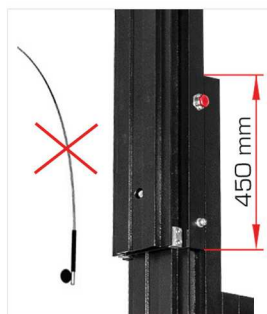

MAYOR TRAMO DE SEGURIDAD.
> EVITA EFECTO CAÑA DE PESCAR.



DGUV Regulation 17&18

MADE IN SPAIN



CARACTERÍSTICAS TÉCNICAS

ULK 500

ALTURA DE TRABAJO	6,30 m
CARGA MÁXIMA	220 kg
PESO NETO	117 kg
MEDIDAS PLEGADA	570 x 460 x 1700 mm
ALTURA DE CARGA	19 cm
Nº DE TRAMOS	5
MEDIDA DEL PERFIL	135 x 89 mm
CABRESTANTE AUTOFRENABLE	Ref. AL-KO 900
CARGA MÍNIMA	20 kg
MATERIAL	ALUMINIO - ACERO
ALEACIÓN	EN-AW 6082 T6 - S235 JRH
COLOR	NEGRO
CONFORME CON	DGUV Regulation 17&18, DGUV Rule 115-002, DIN 56950-1, 2006/42/CE



GUIL®

ULK 500

MADE IN SPAIN



LINE ARRAY

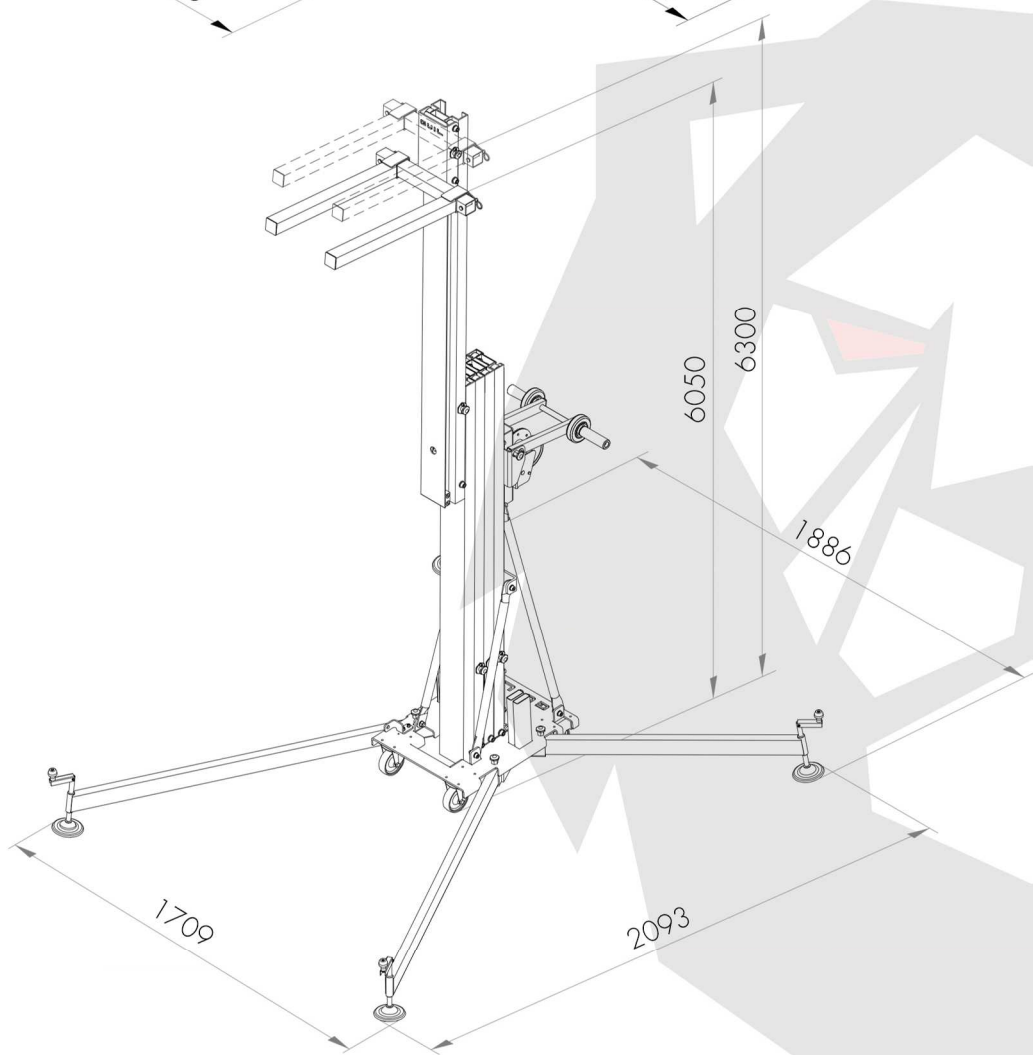
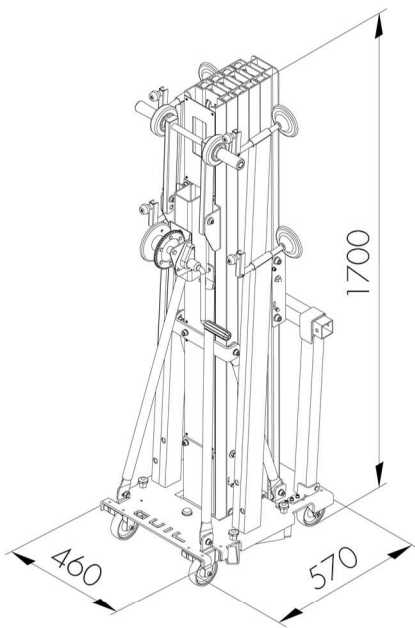
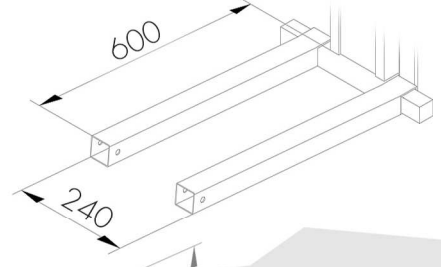
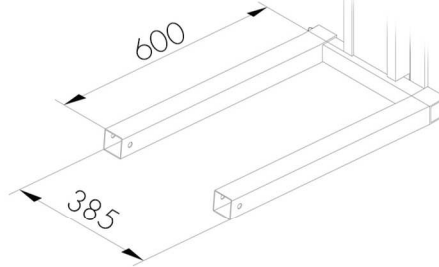

ADAPTADORES PARA ULK

ADAPTADORES PARA LA ELEVACIÓN DE SISTEMAS LINE ARRAY



Ref. **ULK-A6**



Ref. **ULK-A4**

ADAPTADOR ARTICULADO PARA ELEVAR TRUSSES CON TORRES ULK



Ref. **ULK-A10**



360°



GUIL®

ELEVADORES DE CARGA FRONTAL

ULK



DGV Regulation 17&18

Detalles que nos diferencian



Sistema de desbloqueo de los tramos (MSU)



Sistema de seguridad de Bloqueo Automático (ASB)



Cabrestante Autofrenable (AL-KD 900)
Certificado conforme a las normativas Europeas.



Sistema de Freno Pendular Interno (IPB)

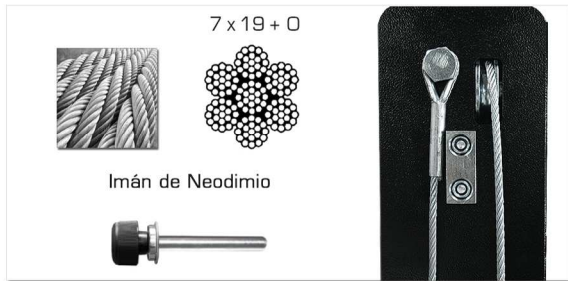

Perfiles de Aluminio reforzado Cable galvanizado. Pasadores de acero inoxidable con imán de Neodimio.



Mayor tramo de seguridad.
> Evita efecto caña de pescar.



4 ruedas (Ø100mm) con núcleo de aluminio y placa de sujeción de acero (4 puntos de sujeción por rueda).



Provistos con horquillas reforzadas de 60x60 mm. Máxima resistencia. Diseño desmontable y ajustable.



Sistema de reenvío con poleas de acero.



Equipados con 4 estabilizadores para una máxima resistencia.



Husillos niveladores de doble paso y velocidad con discos cromados con caucho antideslizante.



Pletina de acero para sujeción del mástil a la base. Adaptador portadocumentos.



Empuñadura abatible con ruedas de Ø100 para el transporte de las ULK en posición horizontal y facilitar su carga en vehículos.