

DECLARACIÓN CE DE CONFORMIDAD EC DECLARATION OF CONFORMITY



El fabricante:
The manufacturer:

GUIL®

GUIL Accesorios Música S.L.

P.I. La Creu C/ Ismael Tomás Alacreu, 28
46250 L'Alcúdia –Valencia – SPAIN

Declara que el modelo:
Declares that the model: Torre para la elevación de equipos Line Array / *Line Array Tower*

Ref.	Carga Máx. / <i>Max. Weight</i>	Altura Máx. de Trabajo / <i>Max. Working Height</i>
TMD-545/N	500 kg	6.25 m

Cumple con los requerimientos de las siguientes normativas:
Complies with the requirements according to the following standards:

- **Directive 2006/42/CE**
- **EN 13814**
- **EN 17206**
- **DGUV Regulations 17 & 18**
- **DGUV Rule 115-002**

La persona facultada para elaborar el expediente técnico es:
The qualified person to create the technical report is:

Salvador Gascó García
P.I. La Creu C/Ismael Tomás Alacreu, 28
46250 – L'Alcúdia, Valencia (SPAIN)

Este producto ha sido sometido a los controles de seguridad y pruebas de resistencia realizadas en la fábrica de producción.
This product has been submitted by the manufacturer to a factory production control and to the further testing of samples taken at the factory.

Firmado:
Signed:

GUIL®
ES B96498829
P.I. LA CREU C/ ISMAEL TOMÁS ALACREU, 28
46250 L'ALCUDIA (VALENCIA) SPAIN
Tel. + 34 962996500 Fax. + 34 962540833
www.guil.es info@guil.es sales@guil.es

Fecha de emisión:
Issued on: **31/01/2022**

Eduardo Hinarejos Chinchilla
(Director general / *General manager*)

El presente certificado es válido salvo suspensión o retirada notificada con tiempo.
This Certificate is valid unless it is cancelled or withdraw upon written notification.

Ingenieure für Ihre Visionen

- Zuverlässig
- Sicher
- Schnell

EXPO
Engineering

Statische Berechnung

Static Analysis

Datum: 04.02.2020
Lieferschein-Nr.: 2020020403
Kunden-Nr.: 53027
Sachbearbeiter/-in: Philip Ottenottebrock

Auftraggeber: GUIL S.L.
Customer: P.I. La Creu C/ Ismael Tomás Alacreu,
28-30
46250 L'ALCÚDIA (VALENCIA) SPAIN
SPANIEN

Projekt: 2019-1351
Project: TMD 545/N - Redesign



Nur gültig und rechtsverbindlich als Original mit Stempel und Unterschrift - Kopien sind rechtswidrig!
Only valid and binding as an original document with stamp and signature - copies are illegal!

Expo Engineering GmbH
Suerkamp 14
D-59302 Oelde
Fon: +49 (0) 2520-93162-0
Fax: +49 (0) 2520-93162-210
www.expo-engineering.de

Hand out - TMD 545/N is checked and approved by Expo Engineering according:

Basics of construction engineering:

- DIN EN 1991 – Eurocode 1: Actions on structures (12/2010)
- DIN EN 1993-1 Eurocode 3: Design of steel structures (12/2010)
- DIN EN 1999-1 Eurocode 9: Design of aluminum structures (05/2010)
- DIN EN 13814 Fairground and amusement park machinery and structures (2005-06)

Accident prevention regulation:

- DGUV commandment 17 (BGV C1): Veranstaltungs- und Produktionsstätten für szenische Darstellungen (04/1998)

Terms for safe use:

- The construction is checked for wind speed up to 8 Beaufort. In the event severe weather warnings of wind speeds greater than 8 Beaufort (17,8 m/s or 64,08 km/h), lower the load and completely disassemble the tower. It is recommended to operate a wind measuring system at the top of the tower.
- Stiffeners for lateral support of the pressure bars must be installed. A total of 2 pieces at a max height with 4 truss elements (4x1,50m).
- The Tower load must not exceed the following values:
live load max. : **500,0 kg**

Wind effected area	Tower height	max. 6,43 m
PA Front	: $A_{Front,PA}$	= 2,5 m²
PA sideways	: $A_{Side,PA}$	= 1,5 m²

- In service state with the max. wind effected areas, counter weights needs to be placed on structure.
height max. 6,43 m : Counter weight 200,0 kg

These Ballast must be increased if the live load is different to the max. load. example: live load 350,0 kg (h =6,43 m)
counter weight: 200,0 + 150,0 = 350,0 kg

- These weights can be modified according the wind affected areas.
- The calculation of both these changes to variables can be done using the Excel-sheet- TMD-545/N. Contact manufacturer for this.

- **Anchoring by weight anchors (ballast)**

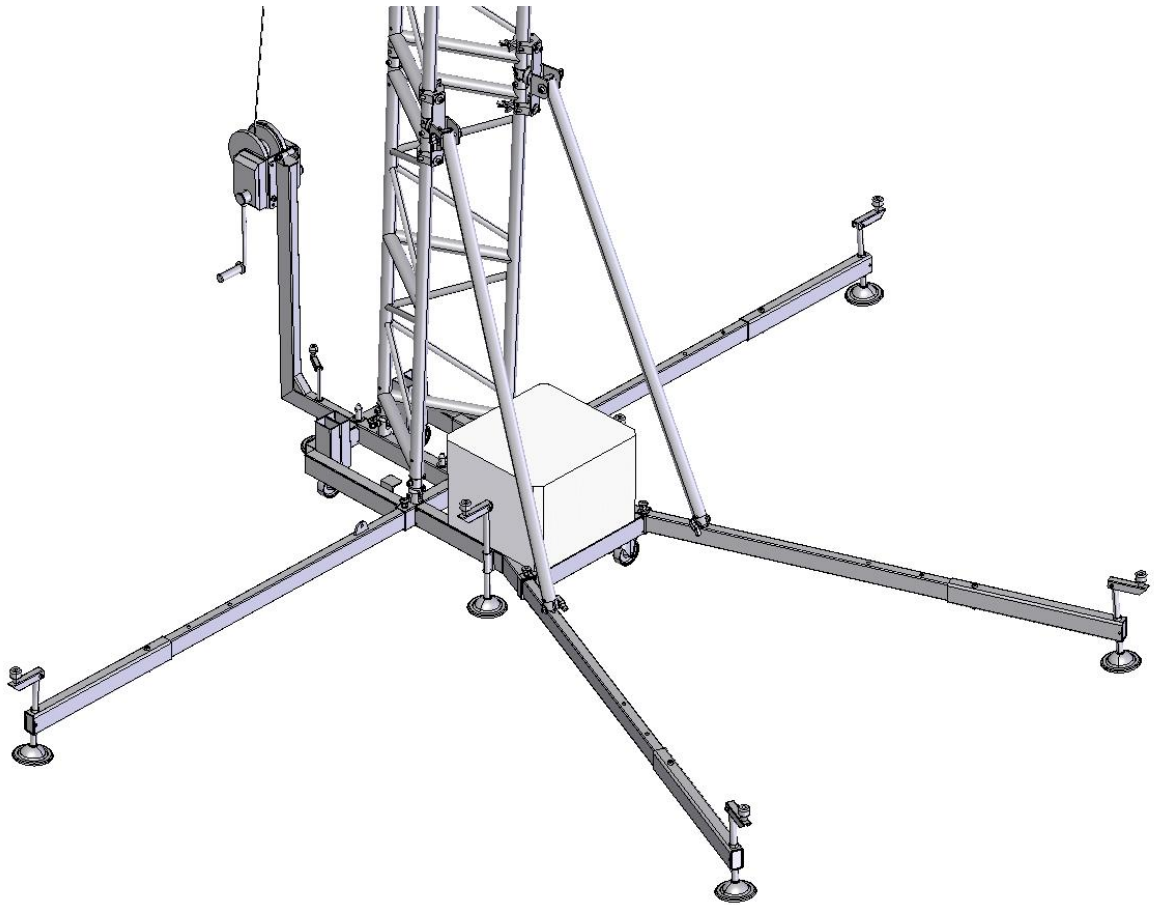

Ballast must be placed direct on the Base frame.

- The structure must be placed on flat ground with sufficient load capacity. For bad ground condition, levelling / pressure spreading activities must be carried out by the user for each individual set-up case. All spindles must be in contact with the ground. Spindles must be set up on pieces of wood.(necessary friction factor).
- The construction must be protected against impact.
- Make sure all connections of the tower and also the load cannot become loose.
- The load is secured at the front attachment point of the head section. For operation, the steel cable of the hand crank must also be attached to the head section and the cable must be pre-tensioned.